**Aerospace — Airframe ball bearings,
double-row, rigid, precision, sealed,
heavy duty — Inch series**

*Aéronautique et espace — Roulements pour structures d'aéronefs:
roulements, rigides, de précision, à deux rangées de billes, avec joints
d'étanchéité, série lourde — Série en inches*

STANDARDSISO.COM : Click to view the full PDF of ISO 14215:1998



Foreword

ISO (the International Organization for Standardization) is a worldwide federation of national standards bodies (ISO member bodies). The work of preparing International Standards is normally carried out through ISO technical committees. Each member body interested in a subject for which a technical committee has been established has the right to be represented on that committee. International organizations, governmental and non-governmental, in liaison with ISO, also take part in the work. ISO collaborates closely with the International Electrotechnical Commission (IEC) on all matters of electrotechnical standardization.

Draft International Standards adopted by the technical committees are circulated to the member bodies for voting. Publication as an International Standard requires approval by at least 75 % of the member bodies casting a vote.

International Standard ISO 14215 was prepared by Technical Committee ISO/TC 20, *Aircraft and space vehicles*, Subcommittee SC 15, *Airframe bearings*.

Annex A of this International Standard is for information only.

STANDARDSISO.COM : Click to view the full PDF of ISO 14215:1998

© ISO 1998

All rights reserved. Unless otherwise specified, no part of this publication may be reproduced or utilized in any form or by any means, electronic or mechanical, including photocopying and microfilm, without permission in writing from the publisher.

International Organization for Standardization
Case postale 56 • CH-1211 Genève 20 • Switzerland
Internet central@iso.ch
X.400 c=ch; a=400net; p=iso; o=isocs; s=central

Printed in Switzerland

Introduction

At the time this International Standard was developed, the Imperial unit sizes of airframe ball bearings were dominant in world application. The basis for this International Standard is the Imperial units provided in annex A. For new applications, the use of metric series airframe ball bearings is encouraged.

STANDARDSISO.COM : Click to view the full PDF of ISO 14215:1998

[STANDARDSISO.COM](https://standardsiso.com) : Click to view the full PDF of ISO 14215:1998

Aerospace — Airframe ball bearings, double-row, rigid, precision, sealed, heavy duty — Inch series

1 Scope

This International Standard specifies the characteristics, boundary dimensions, tolerances, internal clearances and permissible loads of inch series, double-row, sealed, rigid, heavy duty ball bearings with increased precision and reduced internal clearances used in airframe applications. These bearings are full complement (without cage) with a double row of balls and filling slot. These bearings are designed to withstand only slow rotations and oscillations under load and are intended for use between fixed and moving parts of an aircraft structure and their control surfaces.

The airframe ball bearings covered by this International Standard are designed to operate in the temperature range of $-54\text{ }^{\circ}\text{C}$ to $+150\text{ }^{\circ}\text{C}$.

2 Normative references

The following standards contain provisions which, through reference in this text, constitute provisions of this International Standard. At the time of publication, the editions indicated were valid. All standards are subject to revision, and parties to agreements based on this International Standard are encouraged to investigate the possibility of applying the most recent editions of the standards indicated below. Members of IEC and ISO maintain registers of currently valid International Standards.

ISO 683-17:—¹⁾, *Heat-treated steels, alloy steels and free-cutting steels — Part 17: Ball and roller bearing steels.*

ISO 1132:1980, *Rolling bearings — Tolerances — Definitions.*

ISO 2082:1986, *Metallic coatings — Electroplated coatings of cadmium on iron or steel.*

ISO 4520:1981, *Chromate conversion coatings on electroplated zinc and cadmium coatings.*

ISO 5593:1997, *Rolling bearings — Vocabulary.*

ISO 8075:1985, *Aerospace — Surface treatment of hardenable stainless steel parts.*

ISO 14190:1998, *Aerospace — Airframe rolling bearings: ball and spherical roller bearings — Technical specification.*

AMS 2417E:1993, *Plating, zinc-nickel alloy.*²⁾

¹⁾ To be published. (Revision of ISO 683-17:1976)

²⁾ Available from: SAE International
400 Commonwealth Drive
Warrendale, PA 15096-0001
USA

3 Definitions

For the purposes of this International Standard, the definitions given in ISO 5593 apply.

4 Symbols

4.1 For the purposes of this International Standard, the symbols given in ISO 1132 apply. The symbols (except those for tolerances) shown in figure 1 and the values given in tables 1 and A.1 denote nominal dimensions unless specified otherwise.

4.2 Additional symbols for bearings covered by this International Standard are the following.

C_s permissible static radial load

$F_{a\max}$ permissible static axial load

5 Required characteristics

5.1 Dimensions — Tolerances — Internal clearances — Loads

Values are given in table 1. Where plating is specified, tolerances are applicable after plating.

Configuration is given in figure 1. The configuration for and installation process of seals are at the manufacturer's option.

5.2 Surface roughness

Inner and outer ring raceways and rolling elements shall have a surface roughness of $R_a = 0,2 \mu\text{m}$ max.

Bore, side faces and cylindrical outer surface shall have a surface roughness of $R_a = 0,8 \mu\text{m}$ max. before surface treatment.

6 Materials

6.1 Low alloy through hardening bearing steel (code letter F, D, M and Z)

Rings: bearing steel — ISO 683-17, type 1, surface hardness 59 HRC to 64 HRC (710 HV to 840 HV).

Balls: bearing steel — ISO 683-17, type 1, heat treated to 59 HRC to 64 HRC (710 HV to 840 HV).

6.2 Corrosion-resistant stainless steel (code letters C and H)

Rings: bearing steel — ISO 683-17, type 21, hardness ≥ 58 HRC (≥ 670 HV).

Balls: bearing steel — ISO 683-17, type 21, hardness ≥ 58 HRC (≥ 670 HV).

6.3 General

Seals: polytetrafluoroethylene (PTFE) or polytetrafluoroethylene (PTFE) sheet, glass-fabric reinforced.

Seal retainers: corrosion-resistant steel.

7 Surface treatment

7.1 All elements manufactured from corrosion-resistant steel which are not cadmium plated or zinc-nickel plated (code letter C) shall be passivated in accordance with ISO 8075 or cleaned by a mechanical method.

7.2 If made of corrosion-resistant steel, cadmium plating (code letter H) shall be subject to agreement between the customer and the manufacturer.

7.3 Where cadmium plating is specified (code letters D, M and H), it shall be in accordance with ISO 2082. The external surfaces of bearing rings, except the bore of the inner ring, shall be cadmium plated. Plating on the internal surfaces shall be at the manufacturers option, except the raceways shall not be plated. The thickness of the plating shall not be less than 7 µm and not more than 15 µm, except plating on the chamfers of the bore may vary from the specified thickness. The bearing shall be embrittlement-relieved within 4 h of plating by heat treatment at 140 °C ± 10 °C for a minimum of 8 h followed by chromate treatment in accordance with ISO 4520 (code letters D and H only).

7.4 Where zinc-nickel plating is specified (code letter Z), it shall be in accordance with AMS 2417E, type 2. The surface coverage of the plating shall be as specified in 7.3. The thickness of the plating shall not be less than 7 µm or more than 15 µm.

8 Lubrication

The bearing shall be prelubricated with either grease A or B, as specified by the customer.

NOTE — Descriptions of grease A and grease B are given in ISO 14190:1998, annex H.

9 Designation

Bearings in accordance with this International Standard shall be designated only as shown in the following example.

EXAMPLE

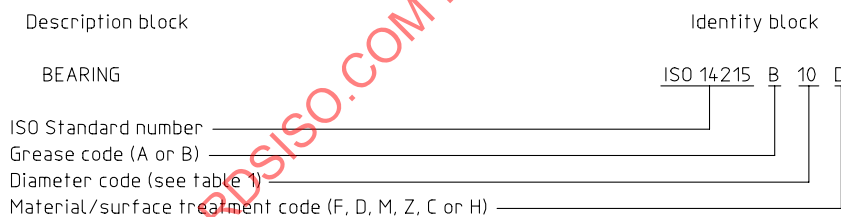

where the following codes are applied:

— greases:

- A = ester type grease;
- B = synthetic hydrocarbon type grease;

— materials/surface treatments:

- F = material: low alloy bearing steel;
surface treatment: none;
- D = material: low alloy bearing steel;
surface treatment: cadmium plated with chromate treatment;
- M = material: low alloy bearing steel;
surface treatment: cadmium plated without chromate treatment;

- Z = material: low alloy bearing steel;
surface treatment: zinc-nickel plated;
- C = material: corrosion-resistant stainless steel;
surface treatment: none;
- H = material: corrosion-resistant stainless steel;
surface treatment: cadmium plated with chromate treatment.

10 Identification marking

In addition to the manufacturer's name or trademark, each bearing shall be permanently and legibly marked, using the identity block as defined in clause 9. Marking position and method are at the manufacturer's option.

11 Technical specification

Airframe ball bearings supplied to this International Standard shall conform to the requirements of ISO 14190.

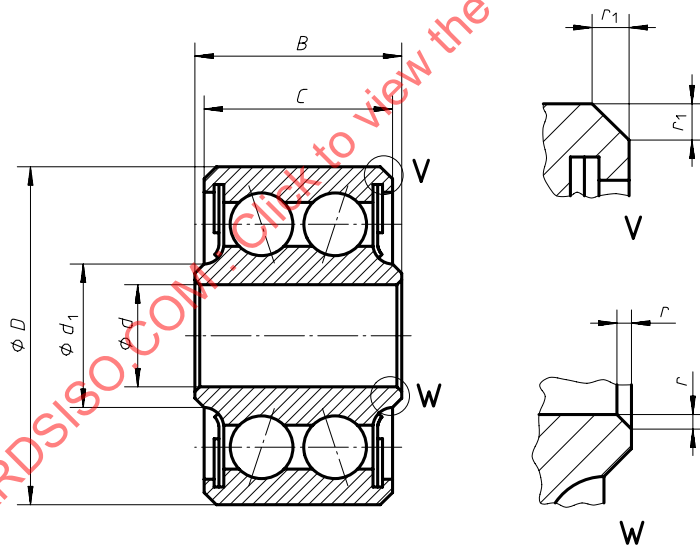

Figure 1

Table 1

Dimensions in millimetres,
tolerances in micrometres

Diameter code	d	D	B	C	Δ_{dmp}	Δ_{Dmp}	V_{Bs}	V_{Cs}	d_1	r	r_1	Mass g \approx
	$\begin{smallmatrix} +3 \\ -10 \end{smallmatrix}$	$\begin{smallmatrix} +5 \\ -15 \end{smallmatrix}$	$\begin{smallmatrix} 0 \\ -64 \end{smallmatrix}$	$\begin{smallmatrix} 0 \\ -64 \end{smallmatrix}$								
03	4,826	19,746	12,573	12,014	0 -8	0 -10	13	13	7,62	0,127 to 0,508	0,457 to 0,838	18
04	6,35	22,896	15,748	12,471					10,41		27	
05	7,938	31,75	18,923	17,45					11,94	0,813 to 1,194	77	
06	9,525	36,512	22,098	20,168					13,97		118	
08	12,7	42,862	23,673	21,742					18,8	1,118 to 1,499	172	
10	15,875	49,212	25,273	23,368					22,61		240	

Diameter code	Internal clearances μm		Runout tolerances max. μm				Starting torque max. mN·m	Permissible static radial load C_s kN	Permissible static axial load $F_{a \max}$ kN
	Radial G_r ref.	Axial G_a max.	Radial		Axial				
			K_{ia}	K_{ea}	S_{ia}	S_{ea}			
03	5 to 13	25 to 51	13	20	18	25	10,6	13,12	7,56
04							23,89	8,01	
05							14,1	48,93	17,79
06							17,7	70,1	23,58
08							28,2	104,98	34,7
10							35,3	126,33	41,81